

Section AA

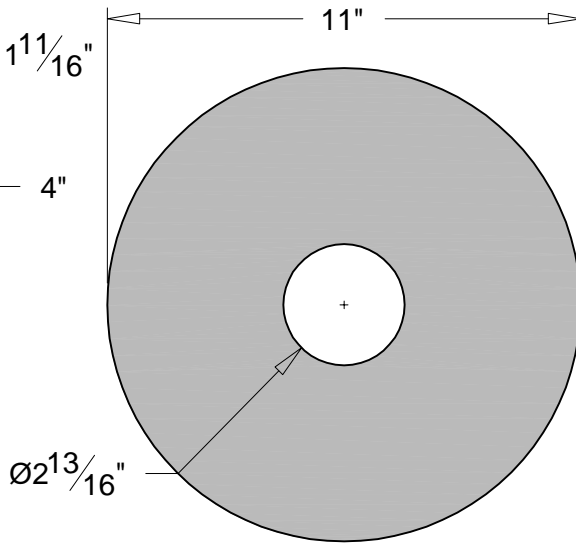
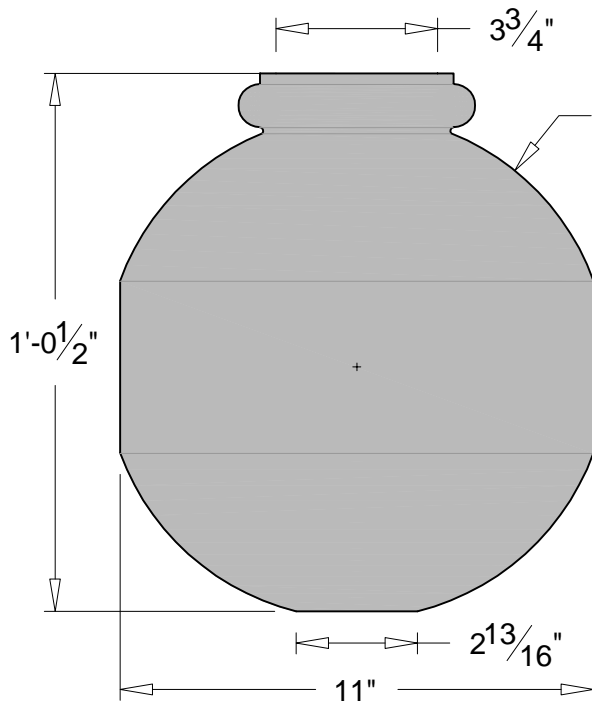

RELATED CASTINGS:
AIC-160 thru AIC-167

Estimated Weight: 80 lbs.

Rev. 1-6-09

THIS DRAWING IS NOT DRAWN TO SCALE
Copyright 2007-2009 Architectural Iron Company, Inc. All rights reserved.

THIS DRAWING IS AN INSTRUMENT OF PROFESSIONAL SERVICE AND SHALL REMAIN THE PROPERTY OF ARCHITECTURAL IRON COMPANY WHETHER THE PROJECT FOR WHICH IT IS PREPARED IS EXECUTED OR NOT. NO CHANGES, ALTERATIONS, ADDITIONS, OR DELETIONS MAY BE MADE EXCEPT BY ARCHITECTURAL IRON COMPANY. THIS DRAWING SHALL NOT BE REPRODUCED BY ANYONE ON OTHER PROJECTS. FOR ADDITIONS TO THIS PROJECT, OR FOR COMPLETION OF THIS PROJECT BY OTHERS WITHOUT WRITTEN CONSENT.

This drawing is available in AutoCad format.

Material used is cast iron unless otherwise specified.

Due to the casting process actual measurements may vary slightly.



Architectural Iron Company

104 Ironwood Court / P.O. Box 126
Milford, PA 18337

800-442-IRON/4766

Fax: 570-296-IRON/4766

www.architecturaliron.com

E-mail: info@architecturaliron.com

New Bern Large Ball

Drawing No.
AIC-161

Drafted By:
B. Hale

Checked By:
D.O.

Date:
09/19/07

Part Number
AIC-161