

Plan View

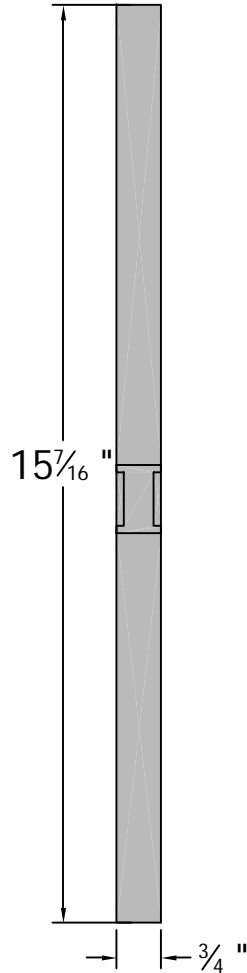

Side Elevation

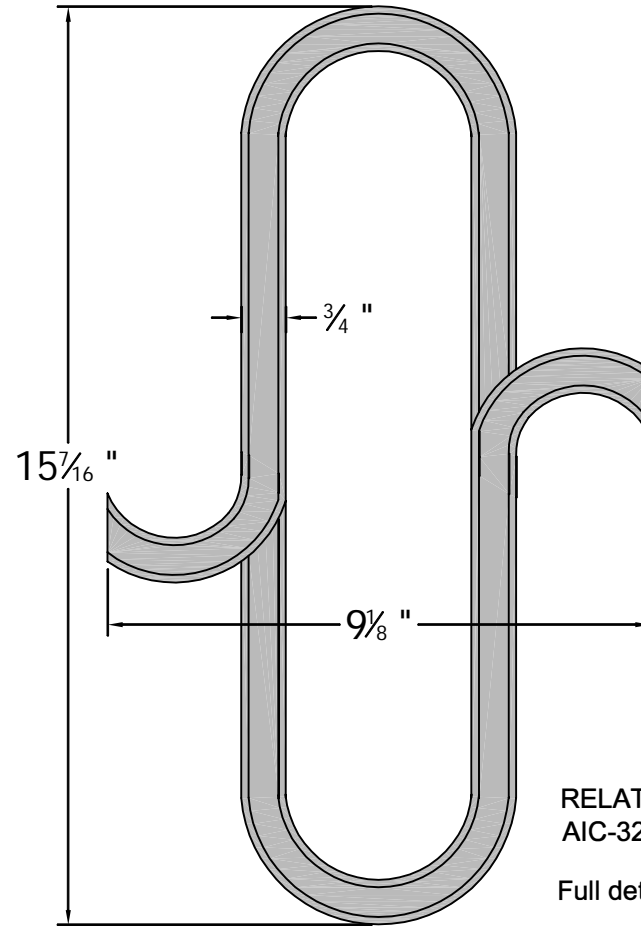

Front Elevation

RELATED CASTING:
AIC-320, 322, 323

Full detail both sides.

Weight: 6 1/2 Lbs.

Rev. 1-8-09

THIS DRAWING IS NOT DRAWN TO SCALE
Copyright 2004, 2007-2023 Architectural Iron Company, Inc. All rights reserved.

THIS DRAWING IS AN INSTRUMENT OF PROFESSIONAL SERVICE AND SHALL REMAIN THE PROPERTY OF ARCHITECTURAL IRON COMPANY WHETHER THE PROJECT FOR WHICH IT IS PREPARED IS EXECUTED OR NOT. NO CHANGES, ALTERATIONS, ADDITIONS, OR DELETIONS MAY BE MADE EXCEPT BY ARCHITECTURAL IRON COMPANY. THIS DRAWING SHALL NOT BE REPRODUCED BY ANYONE ON OTHER PROJECTS, FOR ADDITIONS TO THIS PROJECT, OR FOR COMPLETION OF THIS PROJECT BY OTHERS WITHOUT WRITTEN CONSENT.

This drawing is available in AutoCad format.

Material used is cast iron
unless otherwise specified.

Due to the casting process actual
measurements may vary slightly.



Architectural Iron Company

104 Ironwood Court
Milford, PA 18337

800-442-IRON/4766

Fax: 570-296-IRON/4766

www.architecturaliron.com

E-mail: info@architecturaliron.com

Far Side Horizontal Panel Panel

Drawing No.	Drafted By:	Checked By:	Date:	Part Number
AIC-320	R.Benko	D.O.	7/13/04	AIC-320